

PROJECT PREPARATION

PRE-CONTRACT PHASE:

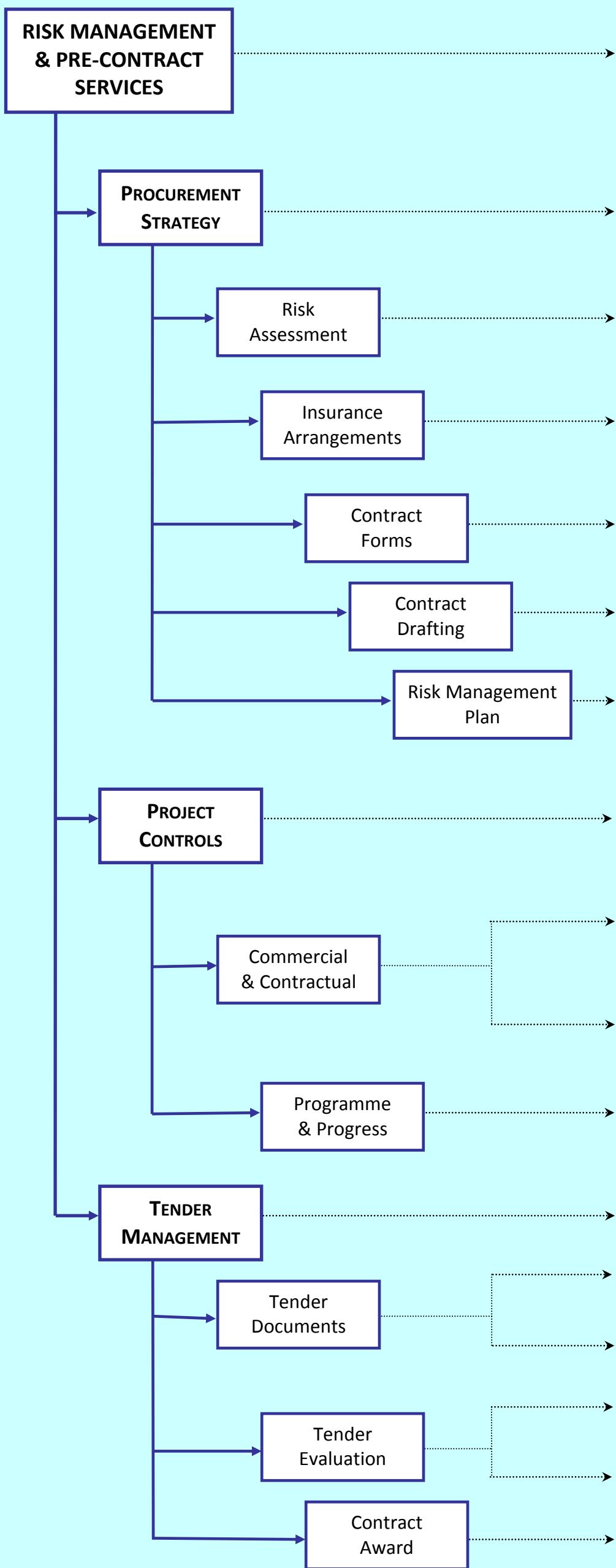

HAMBLETON PROVIDES:

PRE-CONTRACT SERVICES TO ASSIST IN DEVELOPING APPROPRIATE RISK MANAGEMENT & PROCUREMENT STRATEGIES, IN ESTABLISHING EFFECTIVE PROJECT CONTROLS, AND IN THE PREPARATION AND REVIEW OF TENDER DOCUMENTATION

ADVICE ON THE APPROPRIATE PROCUREMENT ROUTE. RECOMMENDATION AND/OR ASSISTANCE IN DECIDING WHETHER IDENTIFIED RISKS ARE TO BE TRANSFERRED, RETAINED, REDUCED OR ELIMINATED AND HOW THIS IS TO BE ACHIEVED

- Comprehensive identification of risks that may impact on the project and establish the likelihood, timing and financial implications of these risks, by means of qualitative and/or quantitative analysis
- Wide-ranging advice and assistance towards securing effective and cost efficient insurance against construction and related risks
- Advice on the most appropriate form of contract to adopt given the clients preferred approach to risk, and advice on the prospective commercial and contractual problems that may arise in adopting a particular 'standard' form
- Drafting of bespoke contract terms and/or particular specifications
- Development of a comprehensive management tool, setting out details of the adopted risk mitigation strategy, procurement and insurance schedules, audit and review timetables and response plans to deal with residual risk

PROJECT CONTROLS TO ASSIST IN THE EFFECTIVE ADMINISTRATION OF THE PROJECT AND TO ASSIST THE CLIENT IN MEETING ITS OBLIGATIONS UNDER THE CONTRACT

- Web based document management systems to enable all members of the client's team to contribute to key management decisions and keep abreast of project correspondence while remote from site
- Procedures and systems to assist the client to manage change and to identify and deal efficiently with other commercial and contractual issues
- Review, or assistance in the preparation of project programmes and the setting up of systems to monitor and manage change from a time perspective

ASSISTANCE IN THE PROCESS OF CALLING AND EVALUATING TENDERS, AND THE AWARD OF CONTRACTS

- Technical audit of tender documentation to avoid incomplete, inconsistent or ambiguous terms
- Preparation and review of tender documents and the drafting of tender instructions
- Assistance in tender queries/negotiations and review and appraisal of submitted tenders
- Review and appraisal of the viability of contractor programmes, method statements and resource proposals
- Assistance in the collation of final contract documents and the drafting of 'wrap-up' letters of award

PROJECT EXECUTION

CONSTRUCTION PHASE:

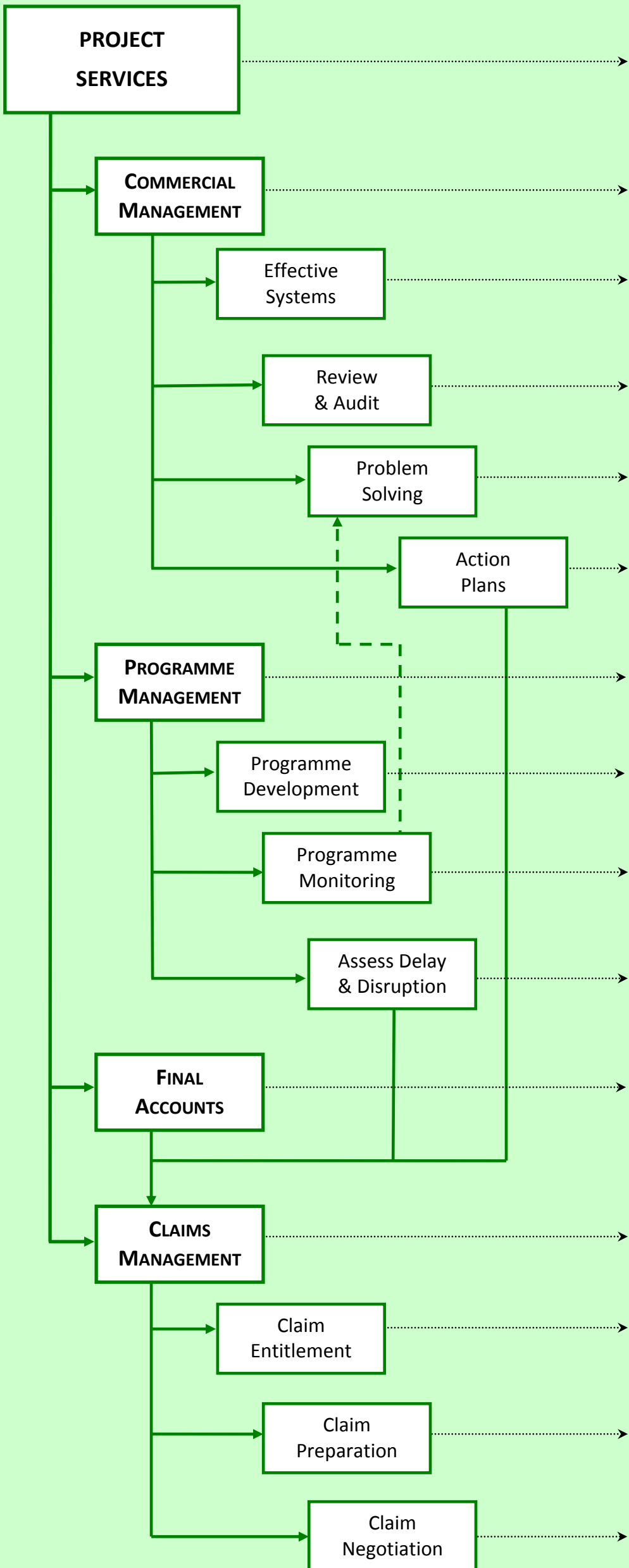

HAMBLETON PROVIDES:

PROJECT SERVICES TO ASSIST IN THE EFFECTIVE ADMINISTRATION AND TO ASSIST THE CLIENT IN MEETING ITS OBLIGATIONS UNDER THE CONTRACT AND/OR SUBCONTRACT(S)

ADVICE AND SUPPORT WITH REGARD TO COMMERCIAL AND CONTRACTUAL ASPECTS OF PROJECT DELIVERY, INCLUDING THE PROVISION OF SUPERVISORY AND/OR SUPPORT STAFF

- Development of management systems for effective contract/subcontract administration and commercial management of the Project
- Continual review (including, where appropriate, remotely via web based management systems) and/or periodic audit of correspondence and of efficacy of commercial management systems
- Early identification of potential problems and efficient solutions
- Advice on the management, containment and resolution of commercial and contractual problems and assistance in preparing key related correspondence, documents and records

ADVICE AND SUPPORT WITH REGARD TO PROJECT PLANNING AND PROGRAMMING / SCHEDULING, INCLUDING:

- Assistance in the preparation, or independent review, of project programmes and of resourcing
- Development and implementation of systems for recording work progress, identifying instances of change, updating project programmes and the reporting of results
- Identification of disturbance to progress and contemporary assessment of extent of delay and/or disruption impacts, and of related entitlement to extensions of time. Advice and support regarding delay mitigation measures

ADVICE AND SUPPORT WITH REGARD TO THE PREPARATION, PRESENTATION AND SETTLEMENT OF FINAL ACCOUNTS

ADVICE AND SUPPORT WITH REGARD TO CLAIMS FOR ADDITIONAL MONETARY AND TIME RELIEF, INCLUDING:

- Detached and objective review of claims entitlement and of likely settlement levels
- Preparation of detailed time and monetary claim submissions or of claims defence documentation suitable for carrying forward to any dispute resolution processes
- Management of claims handling processes and settlement negotiations

PROJECT CLOSE-OUT

POST CONSTRUCTION PHASE:

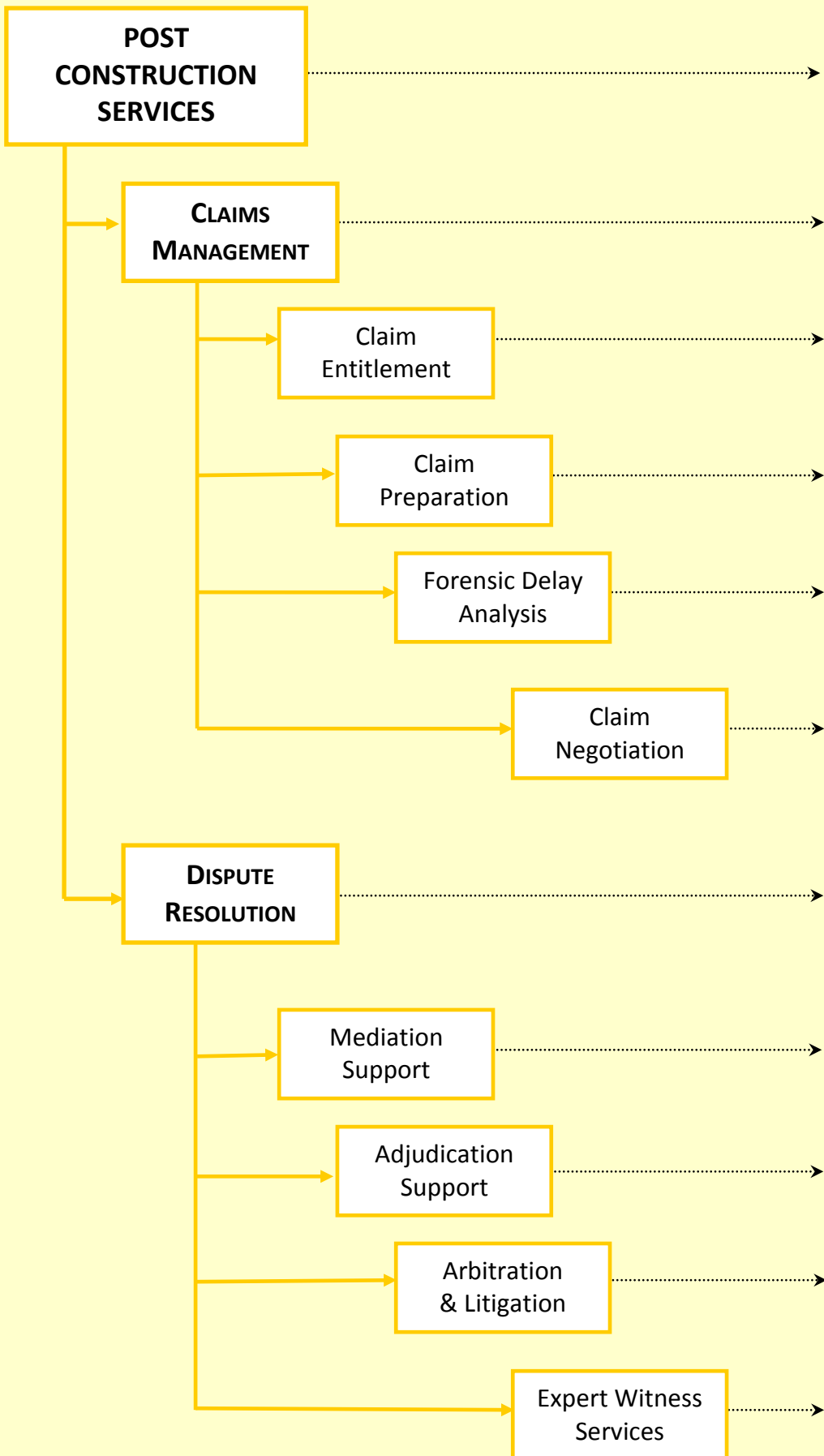

HAMBLETON PROVIDES:

POST CONSTRUCTION SERVICES TO ASSIST IN OBTAINING OPTIMUM FINANCIAL RECOVERY AND IN THE RESOLUTION OF DISPUTES

ADVICE AND SUPPORT WITH REGARD TO CLAIMS FOR ADDITIONAL MONETARY AND TIME RELIEF, INCLUDING:

- Detached and objective review of claims entitlement and of likely settlement levels
- Preparation of detailed claims submission or of claims defence documentation suitable for carrying forward to any dispute resolution process
- Identification of disturbance to the work and contemporary assessment of extent of delay or disruption, and entitlement to extensions of time. Advice and support regarding delay mitigation measures
- Management of claims handling process and settlement negotiations

IN THE EVENT THAT A PARTICULAR ISSUE CANNOT BE RESOLVED BY NEGOTIATION, ASSISTANCE IN DISPUTE MANAGEMENT STRATEGY AND, WHERE APPROPRIATE, IN THE SELECTION OF THE MOST APPROPRIATE PROCEDURE FOR ITS RESOLUTION

- Preparation of position papers and assistance in mediation sessions
- Drafting of adjudication referrals or responses, and support during adjudication process
- Support in the drafting of pleadings; forensic analysis of delay and quantification of cost
- Acting as Expert Witness in relation to matters of time and quantum; provision of related Expert Reports, conducting Expert conclaves and giving verbal evidence